

BS.2... SINGLE STATION SUBPLATE

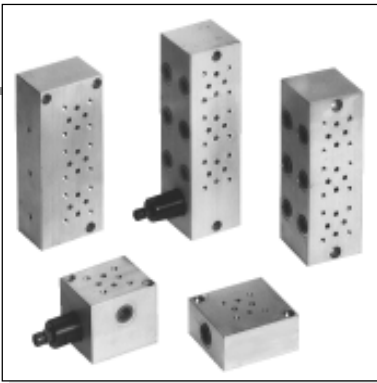

CETOP 2 SUBPLATES

BS.2.**... / BS.2.12...	
BS.2.14...	CH.VII PAGE 2
BS.2.16... / BS.2.20...	
BS.3.2...	CH.VII PAGE 3
BC.2.50.AB... / BC.2.50.PT...	
BC.2.51...	CH.VII PAGE 4
BM.2.**... / BM.2.60...	
	CH.VII PAGE 5
BM.2.50... / BM.2.70...	
	CH.VII PAGE 6
CMP.02...	CH. V PAGE 17

BS.2.**...

- BS** Single subplate (blanking)
- 2** CETOP 2/NG4
- **** **02 / 03 / 04 / 05 / 07**
- 00** No variant
- 1** Serial No.

Weight: 0,09 Kg
 Fixing screws
 M5x25 UNI 5931

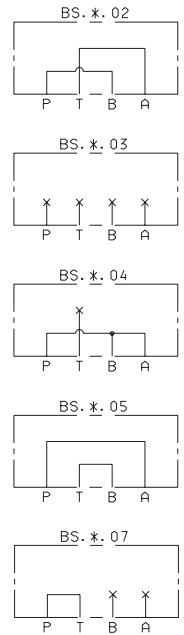
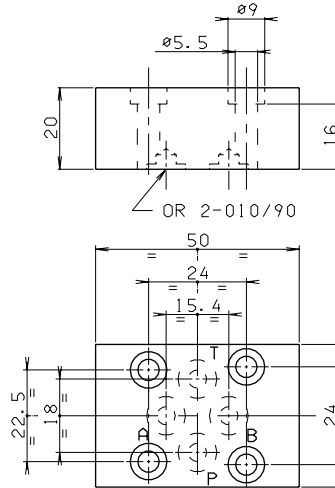

BS.2.12 (REAR CONNECTORS)

- BS** Single subplate
- 2** CETOP 2/NG4
- 12** 1/4" BSP rear connectors
- 00** No variant
- 1** Serial No.

Weight: 0,3 Kg
 Fixing screws M5x35 UNI 5931

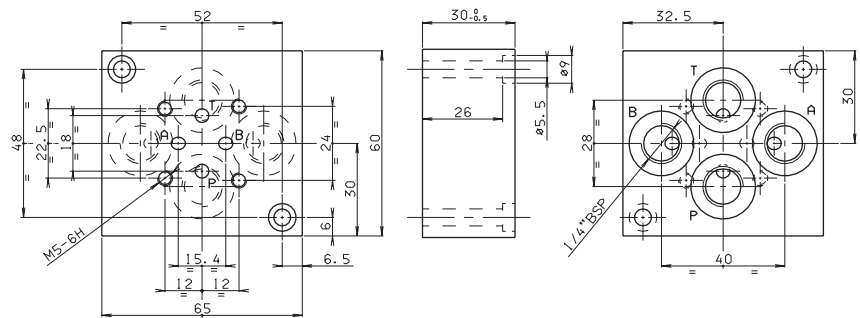

BS.2.14 (SIDE CONNECTORS)

- BS** Single subplate
- 2** CETOP 2/NG4
- 14** 1/4" BSP side connectors
- 00** No variant
- 1** Serial No.

Weight: 0,3 Kg
 Fixing screws M5x35 UNI 5931

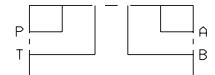
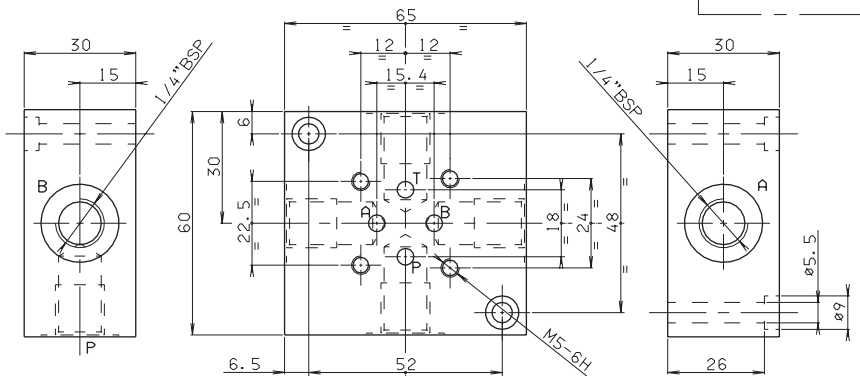

7

BS.2.16 (CONNECTORS SIDE A AND B, REAR P AND T)

- BS** Single subplate
- 2** CETOP 2/NG4
- 16** 1/4" BSP rear and side connectors
- 00** No variant
- 1** Serial No.

Weight: 0,3 Kg
 Fixing screws M5x35 UNI 5931

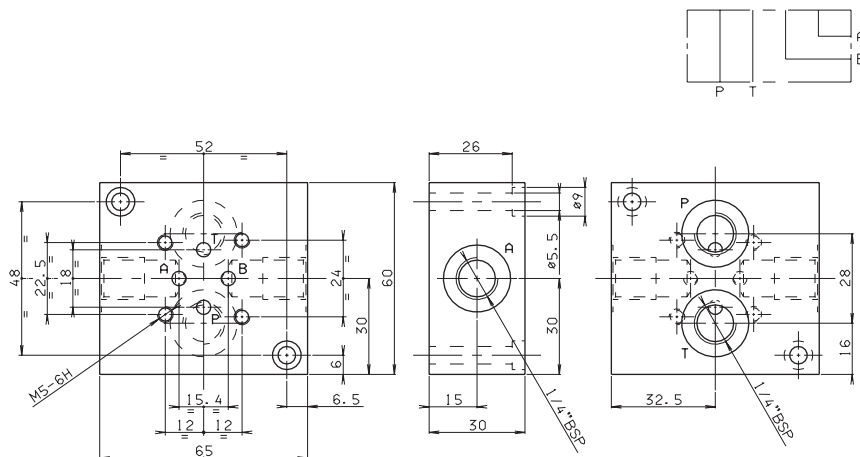

BS.2.20 (CONNECTORS SIDE A AND B, REAR P AND T)

- BS** Single subplate
- 2** CETOP 2/NG4
- 20** 1/4" BSP rear and side connectors
- C** Type of adjustment grub screws
- *** Setting ranges
 - 1 = max. 30 bar (white spring)
 - 2 = max. 90 bar (yellow spring)
 - 3 = max. 180 bar (green spring)
 - 4 = max. 250 bar (orange spring)
- **** 00 = No variant
V1 = Viton
- 1** Serial No.

Weight: 0,45 Kg
 Fixing screws M5x50 UNI 5931

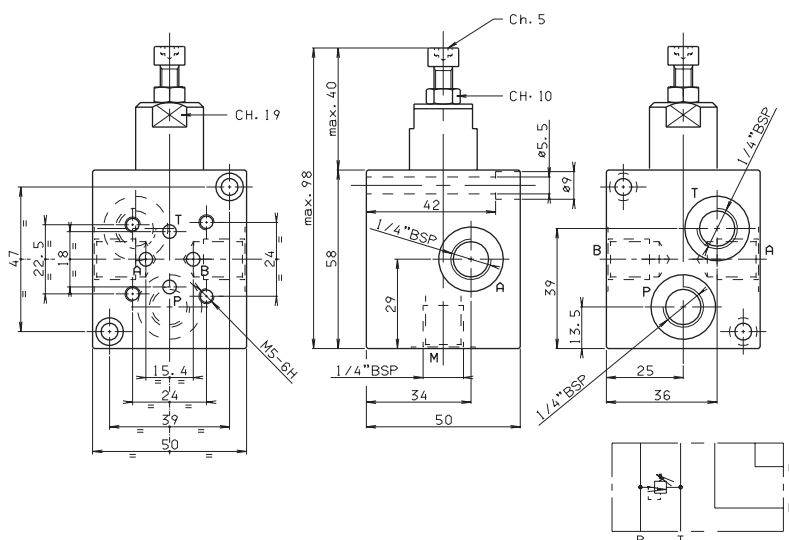

• The minimum permissible setting pressure depending on the spring: see cartridge valve type CMP.02...

BS.3.2 (REDUCTION PLATE FROM CETOP 3/NG6 TO CETOP 2/NG4)

- BS** Single subplate
- 3** CETOP 3/NG6
- 2** CETOP 2/NG4
- 00** No variant
- 1** Serial No.

Weight: 0,12 Kg
 Fixing screws M5x20 UNI 5931

