

BC.3.25/27 P/T REAR AND SIDE CONNECTORS 1/2" BSP- 3 RODS

- BC** Module base
- 3** CETOP 3/NG6
- **** **25** = 1/2" BSP rear and side connectors with CMP
27 = 1/2" BSP rear and side connectors without CMP
- *** Adjustment (omit for 27 version)
M = Plastic knob
C = Grub screw
- *** Setting range (omit for 27 version)
1 = max. 50 bar (**white spring**)
2 = max. 150 bar (**yellow spring**)
3 = max. 320 bar (**green spring**)
- 00** No variant
- 1** Serial No.

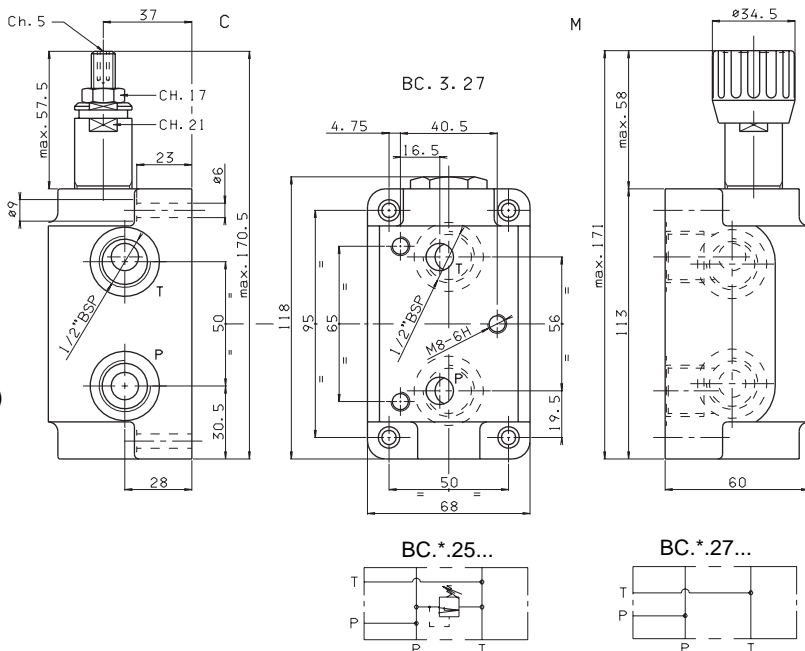

Weight BC.3.25: 2,7 Kg
Weight BC.3.27: 2,6 Kg
Fixing screws M5x30 UNI 5931

• The minimum permissible setting pressure depending on the spring:
see cartridge valve type CMP.10...

ASSEMBLED MODULAR COMPONENT BASES - 3 RODS

Rods code	L	Composition
BC.3.41/2 M80.20.0010	146	BC.3.25/27 + 2 BC.3.30/32 + BC.3.40
BC.3.41/3 M80.20.0011	196	BC.3.25/27 + 3 BC.3.30/32 + BC.3.40
BC.3.41/4 M80.20.0012	246	BC.3.25/27 + 4 BC.3.30/32 + BC.3.40
BC.3.41/5 M80.20.0013	296	BC.3.25/27 + 5 BC.3.30/32 + BC.3.40
BC.3.41/6 M80.20.0014	346	BC.3.25/27 + 6 BC.3.30/32 + BC.3.40
BC.3.41/7 M80.20.0015	396	BC.3.25/27 + 7 BC.3.30/32 + BC.3.40
BC.3.41/8 M80.20.0016	446	BC.3.25/27 + 8 BC.3.30/32 + BC.3.40

Nuts code Q26.56.0514
Pieces 3

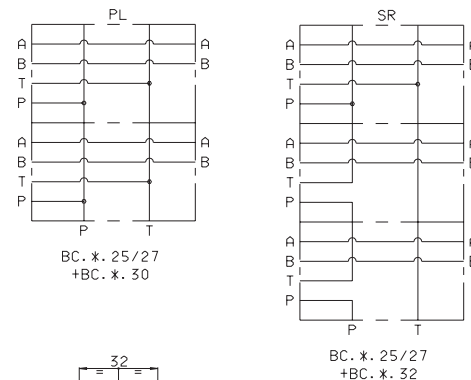

7

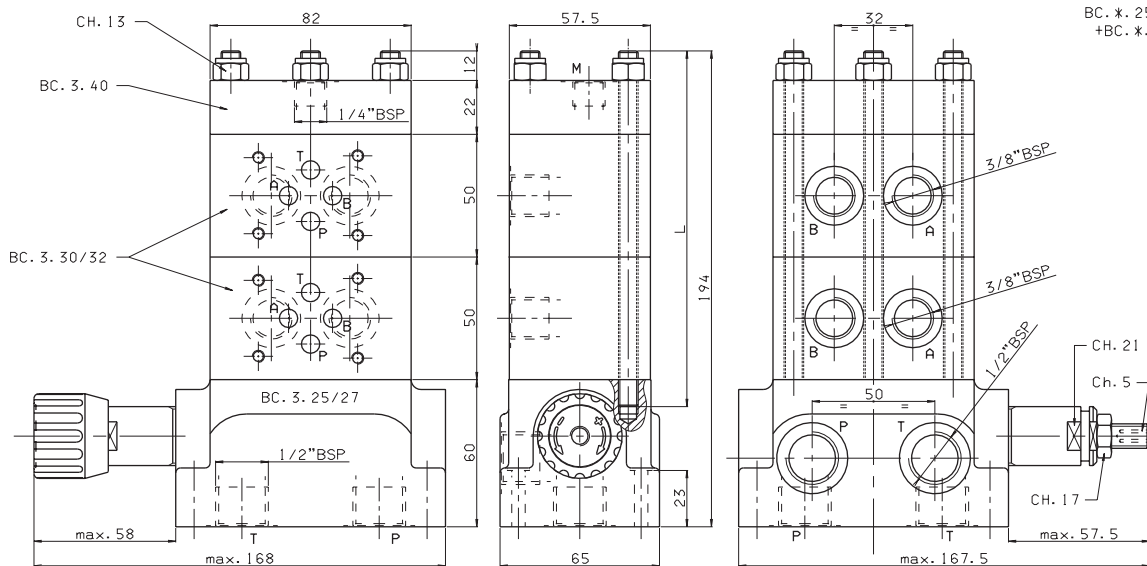

- For series connection the last block high up should be connected in parallel (BC.3.30)
- Single components should be ordered separately
- The minimum permissible setting pressure depending on the spring: see cartridge valve type CMP.10...

BC.3.30/32 - 3 RODS

- BC** Module base
- 3** CETOP 3/NG6
- **** **30** = 3/8" BSP connectors in parallel
32 = 3/8" BSP connectors in series
- 00** No variant
- 1** Serial No.

Weight Kg. 1,4

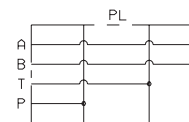
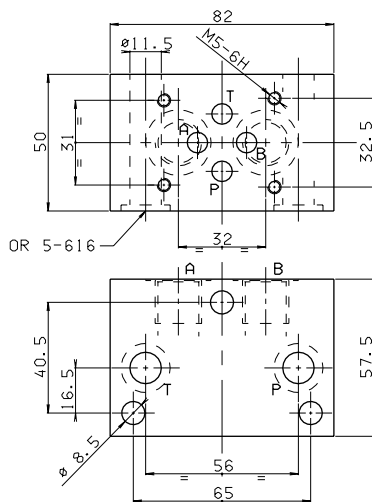

BC.*.30...

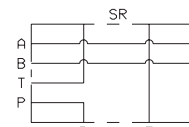

BC.*.32...

BC.3.40 - 3 RODS

- BC** Module base
- 3** CETOP 3/NG6
- 40** Blanking
- 00** No variant
- 1** Serial No.

Weight: 0,7 Kg

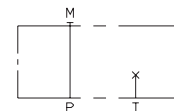
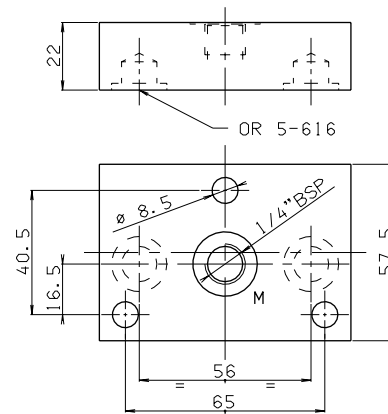

BC.3.41* RODS FOR MODULAR ASSEMBLY

Rod code	Pieces	L	Composition
BC.3.41/2.00.1	3	146	for 2 solenoid valves
BC.3.41/3.00.1	3	196	for 3 solenoid valves
BC.3.41/4.00.1	3	246	for 4 solenoid valves
BC.3.41/5.00.1	3	296	for 5 solenoid valves
BC.3.41/6.00.1	3	346	for 6 solenoid valves
BC.3.41/7.00.1	3	396	for 7 solenoid valves
BC.3.41/8.00.1	3	446	for 8 solenoid valves

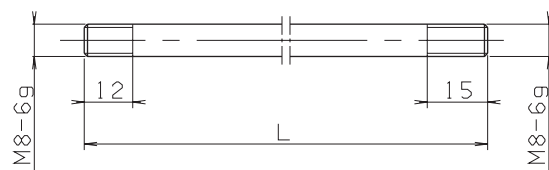

BS.3.W...

- BS** Single subplate
- 3** CETOP 3/NG6
- W** Wheatstone bridge
- 00** No variant
- 1** Serial No.

Weight: 1,8 Kg
Fixing screws M5x45 UNI 5931

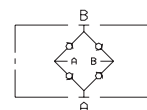
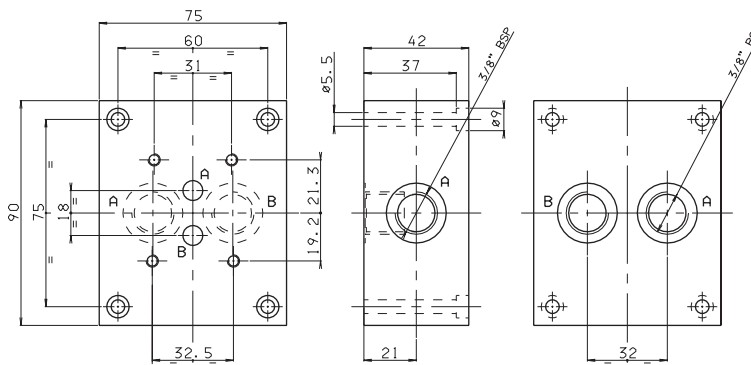

BC.3.50 INTERMEDIATE MODULE FOR PRESSURE GAUGE CONNECTION

- BC** Module base
- 3** CETOP 3/NG6
- 50** Intermediate module for pressure gauge connection at ports A/B/P/T
- 00** No variant
- 1** Serial No.

Module base
 CETOP 3/NG6
 Intermediate module for pressure gauge connection at ports A/B/P/T

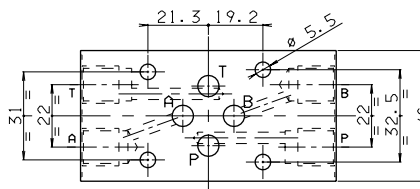
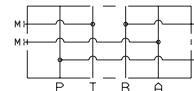
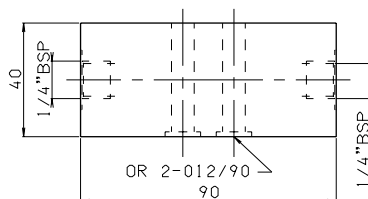

Weight: 1 Kg

BC.3.51 DOWEL BASE PLATE FOR SOLENOID VALVE

- BC** Module base
- 3** CETOP 3/NG6
- 51** Dowel base plate
- 00** No variant
- 1** Serial No.

Module base
 CETOP 3/NG6
 Dowel base plate
 No variant
 Serial No.

CALIBRATED DIAPHRAGMS AVAILABLE	
d	M8x1x8
0.6	M89.10.0007
0.7	M89.10.0008
0.8	M89.10.0009
0.9	M89.10.0012
1	M89.10.0010
1.2	M89.10.0011
1.4	M89.10.0038
1.5	M89.10.0035
1.75	M89.10.0042
2	M89.10.0041
2.5	M89.10.0036

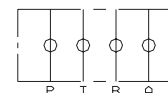
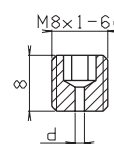
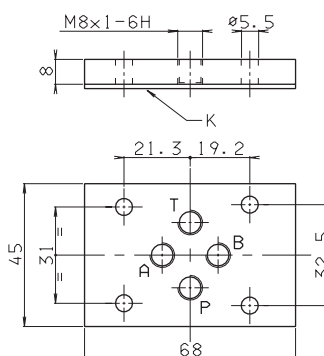

Weight: 0,2 Kg
 K = plate OR (Q25.95.0001)

BC.3.07 BASE PLATE FOR DOUBLE FLOW RATE P→A AND B→T

- BC** Module base
- 3** CETOP 3/NG6
- 07** bases plate for twin flow rate
- 00** No variant
- 1** Serial No.

Module base
 CETOP 3/NG6
 bases plate for twin flow rate
 No variant
 Serial No.

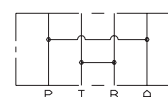
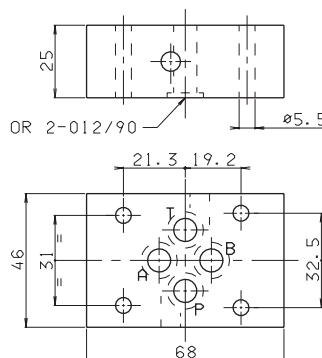

Weight: 0,5 Kg

BC.3.107 BASE PLATE FOR USING 4 WAY VALVE AS 2 WAY ONLY

- BC** Module base
- 3** CETOP 3/NG6
- 107** base for using 4 way valve as 2 way only
- 00** No variant
- 1** Serial No.

Module base
 CETOP 3/NG6
 base for using 4 way valve as 2 way only
 No variant
 Serial No.

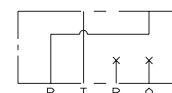
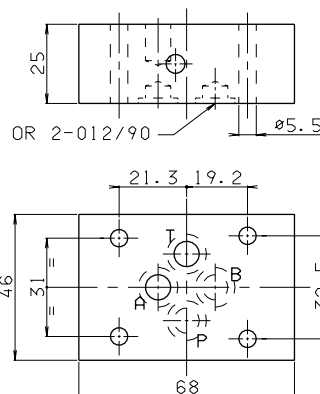

Weight: 0,5 Kg

7