

AD.5.RI... AUTOMATIC RECIPROCATING VALVES CETOP 5

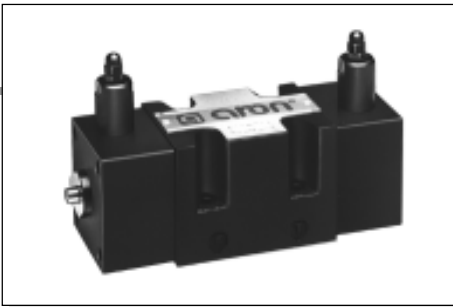

1



AD.5.RI...

This valve type is characterized by a fully hydraulic operation, as it takes advantage of the system pressure rise to cause an automatic and continuous inversion of the utilization. The changeover takes place when the system pressure exceeds the inversion valves calibration pressure, and therefore also in not predetermined position. At the cylinder stroke end, the overall maximum pressure valve should be adjusted on a value 30% higher than the system operating pressure. The inverter valves pressure calibration values should be 15% lower than that of the overall maximum pressure valve, and 15% higher than the maximum operating pressure.

Max. operating pressure	320 bar
Max. pressure port T	160 bar
Min. recommended pressure	15 bar
Max. flow	70 l/min
Min. flow	6 l/min
Setting ranges:	Spring 1 15 ÷ 50 bar
	Spring 2 20 ÷ 140 bar
	Spring 3 50 ÷ 320 bar
Fluid viscosity	10 ÷ 60 mm ² /s
Fluid temperature	-20°C ÷ 75°C
Max. contamination level	class 10 in accordance with NAS 1638 with filter β ₂₅ ≥ 75
Weight	5,4 Kg

Note: to operate the push button emergency, a minimum pressure of 3 bar on the actuator is needed.

ORDERING CODE

AD	Directional valve
5	CETOP 5/NG10
RI	Automatic reciprocating valve hydraulically operated automatic reciprocation
211	Scheme
*	Setting ranges: 1 = 15 ÷ 50 bar 2 = 20 ÷ 140 bar 3 = 50 ÷ 320 bar
**	00 = No variant V1 = Viton
3	Serial No.

HYDRAULIC SYMBOL

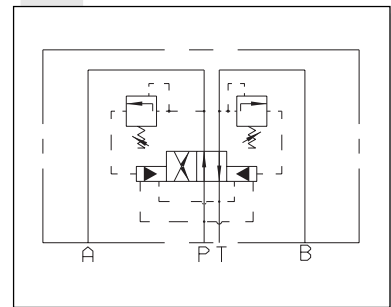

PRESSURE DROPS

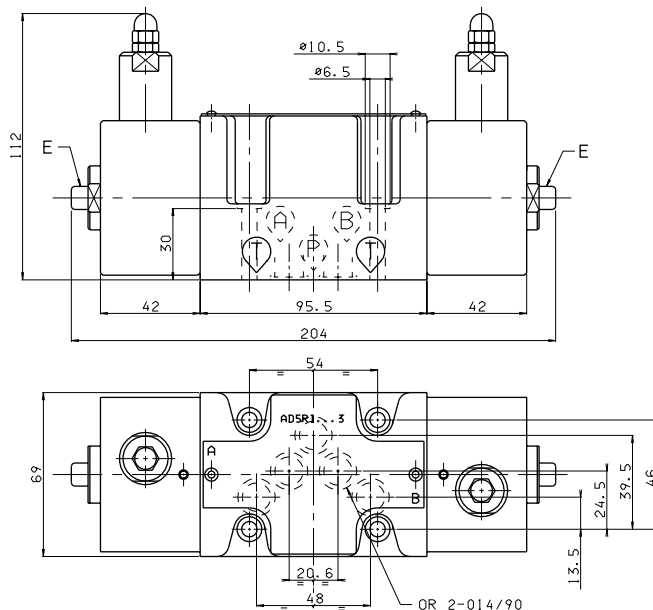
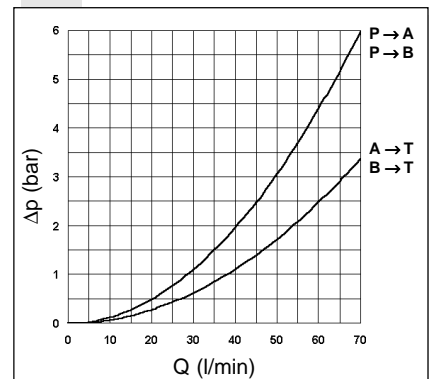

E = Manual override

Fixing screws UNI 5931 M6x40 with material specification 12.9
Tightening torque 8 Nm / 0.8 Kgm

Support plane specifications

