

AD.3.M... MECHANICALLY OPERATED TYPE VALVES CETOP 3/NG6

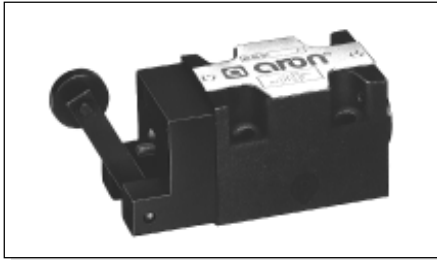

1



| | |
|----------------------------|---|
| Max. pressure ports P/A/B | 320 bar |
| Max. pressure port T | 160 bar |
| Max. flow | 60 l/min |
| Minimum operating force* | 2,5 Kg |
| Maximum operating force ** | 13 Kg |
| Cam angle | 27° |
| Fluid viscosity | 10 ÷ 500 mm ² /s |
| Fluid temperature | -25°C ÷ 75°C |
| Ambient temperature | -25°C ÷ 60°C |
| Max. contamination level | class 10 in accordance with NAS 1638 with filter $\beta_{25} \geq 75$ |
| Weight | 1 Kg |

- Possible mountings: E / F / G / H
- Ordering code see page before
- Note:
 - (*) In the absence of counter-pressure at port T
 - (**) with a pressure of 160 bar at port T

OVERALL DIMENSIONS

Stroke 12,4 mm
Working stroke 3 mm

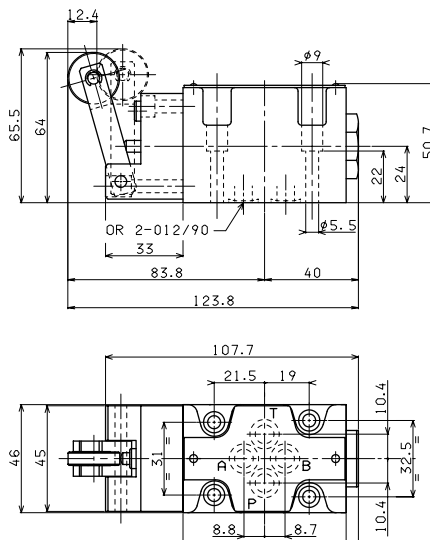

Fixing screws UNI 5931 M5x30 with material specification 12.9
Tightening torque 5 Nm / 0.5 Kgm

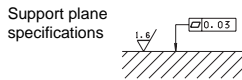

File: EAD3M002

00/2000/e

AD.3.D... DIRECT MECHANICALLY OPERATED TYPE VALVES CETOP 3/NG6



| | |
|---------------------------|---|
| Max. pressure ports P/A/B | 320 bar |
| Max. pressure port T | 20 bar |
| Max. flow | 60 l/min |
| Operating force* | 6 Kg |
| Fluid viscosity | 10 ÷ 500 mm ² /s |
| Fluid temperature | -25°C ÷ 75°C |
| Ambient temperature | -25°C ÷ 60°C |
| Max. contamination level | class 10 in accordance with NAS 1638 with filter $\beta_{25} \geq 75$ |
| Weight | 1,5 Kg |

- Possible mountings: E / F / G / H
- Ordering code see page before
- Note:
 - (*) In absence of counter-pressure at port T

OVERALL DIMENSIONS

Stroke 6 mm
Extra stroke 2 mm
Working stroke 3 mm

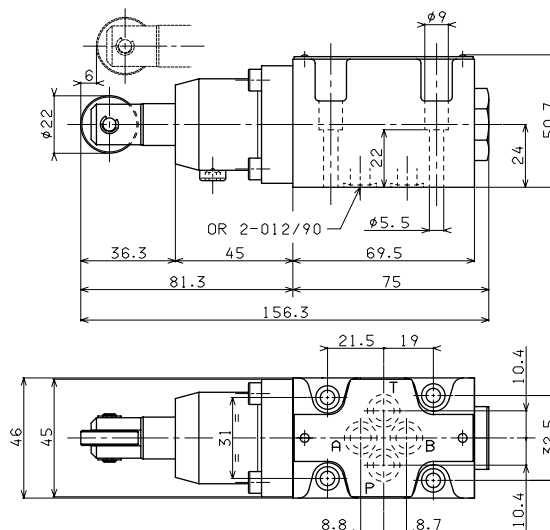

Fixing screws UNI 5931 M5x30 with material specification 12.9
Tightening torque 5 Nm / 0.5 Kgm

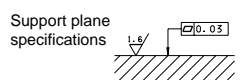

File: EAD3D002

01/2000/e