

AM.3.VM... / AM.3.VI... MODULAR MAX. PRESSURE VALVES CETOP 3



AM.3.VM / AM.3.VI...

CMP.10... CH.V PAGE 19
SCREWS AND STUDS CH.IV PAGE 21

AM.3.VM type pressure regulating valves are available with a pressure range of 2 ÷ 320 bar.

Adjustment is by means of a grub screw or a plastic knob.

Three basic versions are available:
- AM3VM on single A or B lines, and on A and B lines, with drainage to T;
- AM3VMP on single P line, with drainage to T;
- AM3VI on single A or B lines, and on A and B lines, with crossed drainage on A or B (see hydraulic symbols).
All versions can accept three types of springs with calibrated ranges as shown in the specifications.

Max. operating pressure	320 bar
Setting ranges:	spring 1 max. 50 bar spring 2 max. 150 bar spring 3 max. 320 bar
Max. flow	40 l/min
Hydraulic fluids	Mineral oils DIN 51524
Fluid viscosity	10 ÷ 500 mm ² /s
Fluid temperature	-25°C ÷ 75°C
Ambient temperature	-25°C ÷ 60°C
Max. contamination level	class 10 in accordance with NAS 1638 with filter $\beta_{25} \geq 75$
Weight AM.3.VM.A/B/P...	1,2 Kg
Weight AM.3.VM.AB...	1,3 Kg
Weight AM.3.VI.A/B...	2 Kg
Weight AM.3.VI.AB...	2,2 Kg

The cartridge, which is the same for all versions, is the direct acting type CMP10.

For the minimum permissible setting pressure depending on the spring, see minimum pressure setting curve.

ORDERING CODE

AM	Modular valve
3	CETOP 3/NG6
**	VM = Maximum pressure VI = Maximum pressure crossline
**	Adjustment on the lines AM.3.VM Version = A / B / P / AB AM.3.VI Version = A / B / AB
*	Type of adjustment M = Plastic knob C = Grub screw
*	Setting ranges at port A/B/P 1 = max. 50 bar (white spring) 2 = max. 150 bar (yellow spring) 3 = max. 320 bar (green spring)
*	Setting ranges at port B (Omit if the setting is same as that at port A) 1 = max.50 bar (white spring) 2 = max.150 bar (yellow spring) 3 = max. 320 bar (green spring)
**	00 = No variant V1 = Viton
3	Serial No.

PRESSURE - FLOW RATE

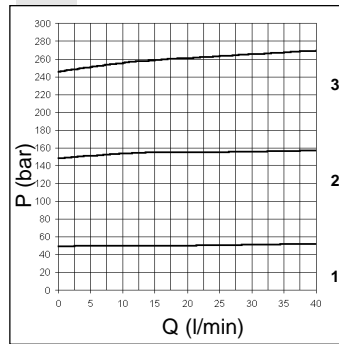

Curves n° 1 - 2 - 3 = setting ranges

MINIMUM SETTING PRESSURE

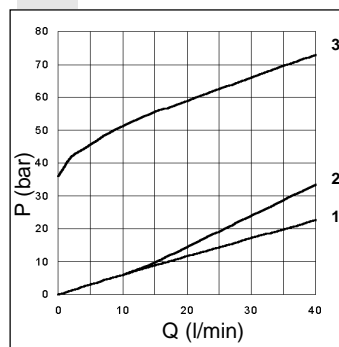

HYDRAULIC SYMBOLS

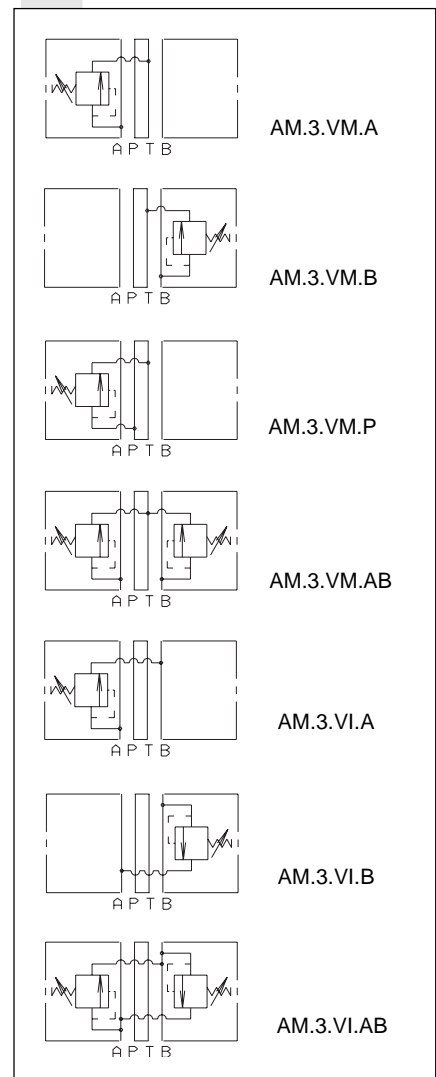

OVERALL DIMENSIONS

AM.3.VM.AB...

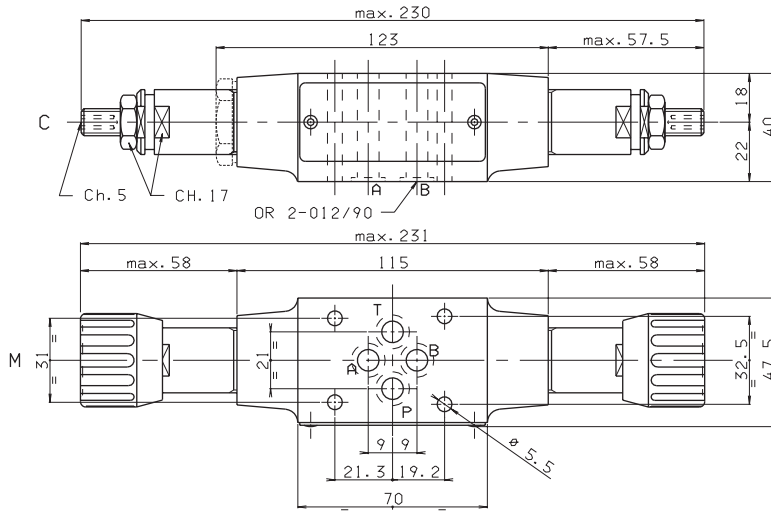

Type of adjustment

- M Plastic knob
- C Grub screw

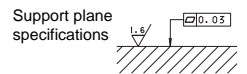

4

AM.3.VM.P...

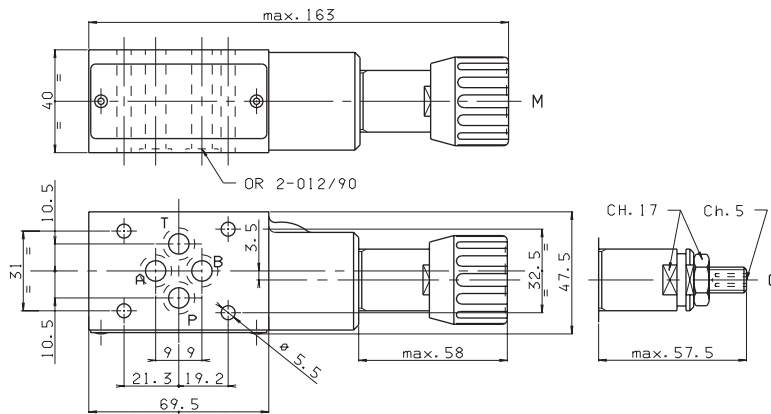

Type of adjustment

- M Plastic knob
- C Grub screw

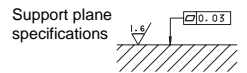

AM.3.VI.AB...

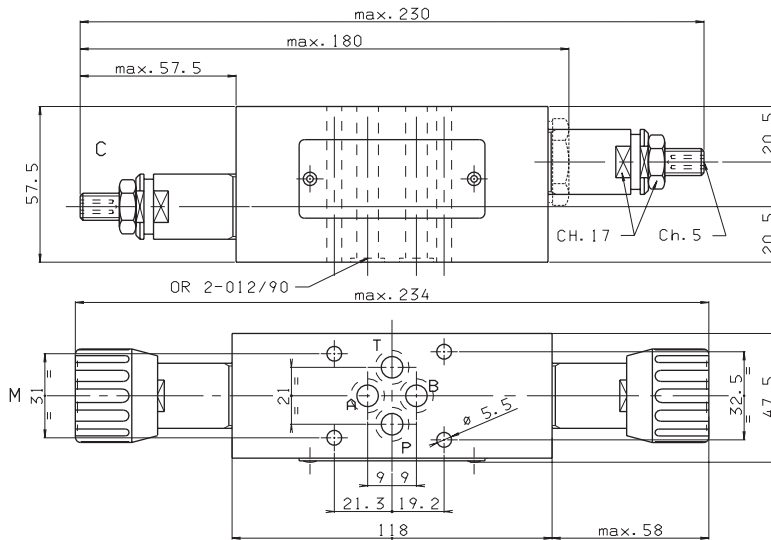

Type of adjustment

- M Plastic knob
- C Grub screw

