

AM.3.SH... MODULAR SHUTTLE VALVES CETOP 3



AM.3.SH...

SH.03... CH. V PAGE 16
SCREWS AND STUDS CH.IV PAGE 21

Modular valves type AM.3.SH are actuator load pressure selecting units, as they are fitted with an integral shuttle valve cartridge which allows taking of the highest pressure signal to the external port via displacement of a ball. They are usually employed to signal the actuator load to the pressure compensator of load sensing pump, or for the command of fail-safe brakes.

For seat overall dimensions see cartridge shuttle SH.03 type.

Max. operating pressure	320 bar
Max. flow at the cartridge	3 l/min
Max. flow at ports A/B/P/T	40 l/min
Hydraulic fluids	Mineral oils DIN 51524
Fluid viscosity	10 ÷ 500 mm ² /s
Fluid temperature	-25°C ÷ 75°C
Ambient temperature	-25°C ÷ 60°C
Max. contamination level	class 10 in accordance with NAS 1638 with filter $\beta_{25} \geq 75$
Weight	1 Kg
Cartridge tightening torque	20÷30 Nm/2÷3 Kgm

ORDERING CODE

- AM** Modular valve
- 3** CETOP 3/NG6
- SH** Cartridge shuttle
- **** **00** = No variant
V1 = Viton
- 1** Serial No.

PRESSURE DROPS ON THE SHUTTLE VALVE

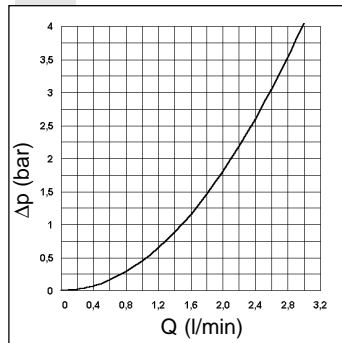

HYDRAULIC SYMBOL

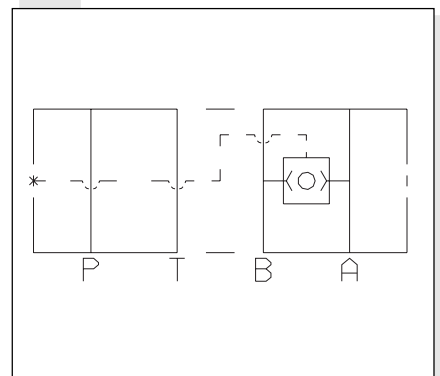

OVERALL DIMENSIONS

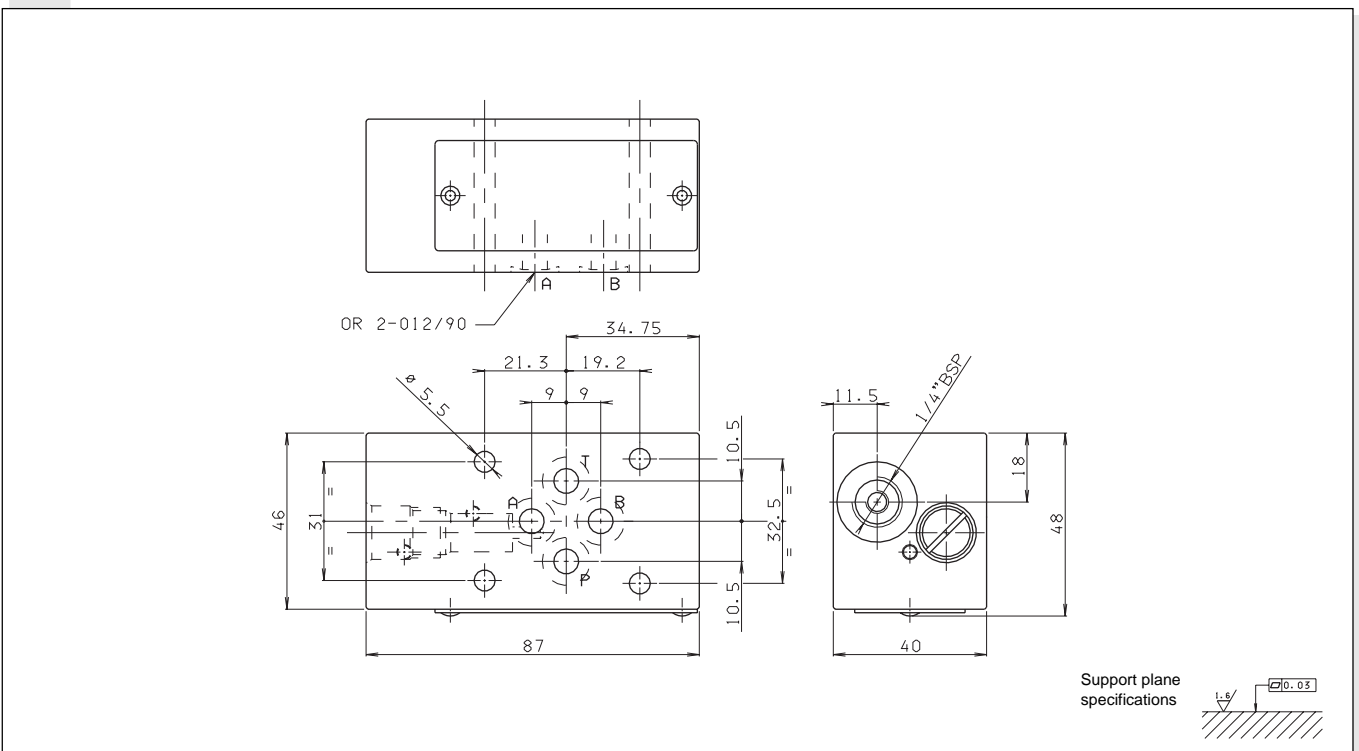

Support plane specifications
1.6 / 0.03