

QFSU... QFSB... IN LINE MOUNTING

FLOW CONTROL VALVES



QFSU... / QFSB...

Two-way adjustable flow regulating valves type QFSU / QFSB allow flow in both directions. Their operation depends on the fluid pressure and viscosity. Flow regulation is obtained by turning a knurled knob, which is provided with a mechanical clamp to ensure holding of the set value even in the presence of system vibrations. The special needle configuration allows an easy and precise control. The body of these valves is zinc-plated yellow steel made, while the internal components are manufactured in heat-treated steel. Their particular construction permits both panel and in-line mounting.

Max. operating pressure	300 bar
Standard opening pressure (For QFSU only)	0,5 bar
Max. flow	40 l/min
Hydraulic fluid	Mineral oils DIN 51524
Fluid viscosity	2.8 ÷ 380 mm ² /s
Fluid temperature	-20°C ÷ 70°C
Max. contamination level	class 10 in accordance with NAS 1638 with filter β ₂₅ ≥ 75
Weight	See table below

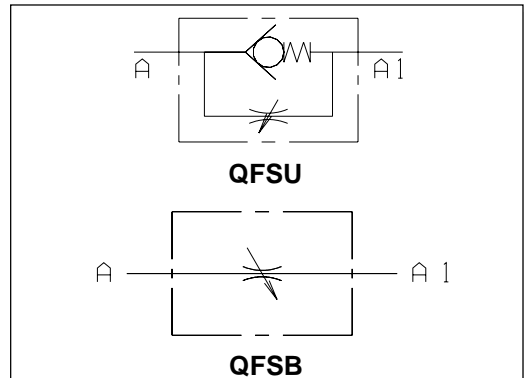

ORDERING CODE

- QFS** Flow control valve
- *** U = One-way valve
B = Two-way valve
- **** Size
07
10
13
- 1** Opening pressure
0.5 bar (standard)
(for QFSU version only,
omit for QFSB version)
- 00** No variant
- 1** Serial No.

Test carried out with mineral based oil with a viscosity of 24 mm²/s at 50°C

PRESSURE DROPS - FLOW

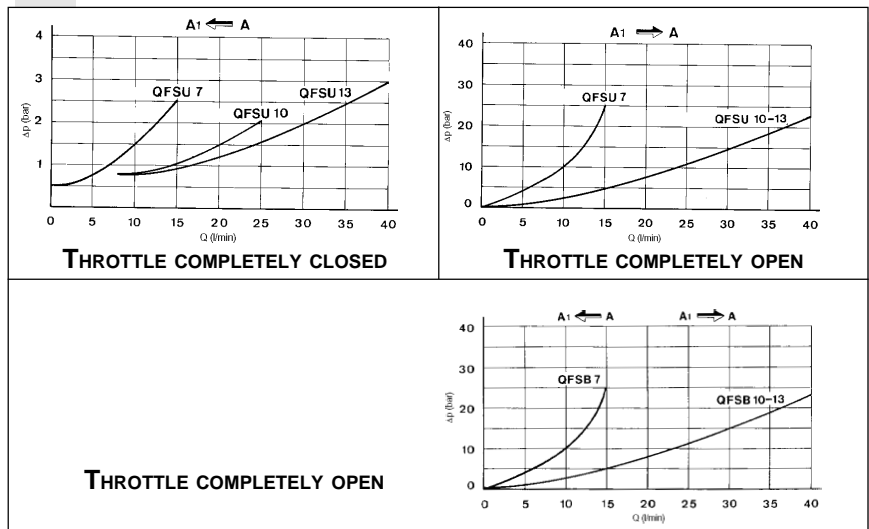

OVERALL DIMENSIONS

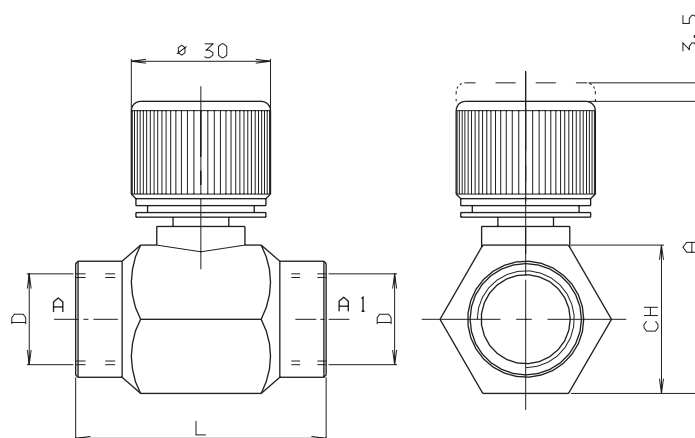

Valve type	Valve type	Max flow (l/min)	Max. pressure (bar)	L	A	D	CH	Weight (Kg)
QFSU07	QFSB07	15	300	54	64	1/4"BSP	32	0.30
QFSU10	QFSB10	25	300	62	64	3/8"BSP	32	0.31
QFSU13	QFSB13	40	280	62	64	1/2"BSP	32	0.31