

## 2/2 CARTRIDGE VALVES LOGIC ELEMENTS ACCORDING TO ISO 7368 (DIN 24342)



ARON cartridge valves are basically composed of a cover and an operating unit insert in the ISO 7368 (DIN 24342) mounting frame. Each cartridge valve is characterized by 2 main way for the nominal flow (up to 350 l/min).

Nominal size (max. diameter)	16mm / 25mm
Max. opening pressure	350 bar
Max. nominal flow rate NG16	150 l/min
Max. nominal flow rate NG25	350 l/min
Fluid temperature	-20°C ÷ 75°C
Max. contamination level	class 10 in accordance with NAS 1638 with filter $\beta_{25} \geq 75$

By combining the various covers, operating units and connections within the block, many different functions can be obtained like: direct control, non-return, hydraulically piloted non-return, pressure control, flow rate regulation, as well as a combination of these same functions.

Thanks to their design features and operational flexibility, cartridge valves can be used to:

- speed-up machine cycles, and therefore increase productivity and efficiency (better response time compared to traditional valves);
- ensure minimum thermal dissipation (thanks to the passageway dimensions);
- reduce the hydraulic plant weight (thanks to the compact functions block);
- reduce to a minimum any internal leakages;
- provide ease of installation and serving.

The logic units 2/2 (Fig. 1) are formed by a cover (1), a functional unit (2), a spacer (3), a closure spring (4) and a guide bush (5) for each functional unit. Covers can be changed according to the required application and the functional unit can be combined with different springs in order to obtain various opening pressure.

### Covers

Covers serve to enclose the functional unit and to house the piloting ports and any incorporated valves or manual adjustment devices. Inside the cover are housed also the seats for the calibrated orifice used to optimize the valve opening/closed response time in according to the type of hydraulic system being implemented.

CETOP 3 interface covers are available, ready to accept solenoid valves or other modular valves for the implementation of particular control functions.

**The maximum allowed pressure is a function of the flow rate (max.400 bar).**

**Fig. 1 - AREA RATIO**

<b>A</b>	MAIN FLOW
<b>B</b>	MAIN FLOW
<b>X</b>	EXTERNAL PILOTING
<b>Z1</b>	EXTERNAL PILOTING
<b>Z2</b>	EXTERNAL PILOTING
<b>Y</b>	DRAINAGE
<b>A1</b>	A PORT EFFECTIVE CROSS SECTION
<b>A2</b>	B PORT EFFECTIVE CROSS SECTION
<b>A3</b>	SPRING CHAMBER EFFECTIVE CROSS SECTION

### ORIFICE FUNCTIONAL SYMBOLS

	STANDARD ORIFICE (ALREADY INSERTED) Ø 1mm (DIAMETER)
	A GRUB SCREW ORIFICE CAN BE INSERTED IN THE THREADED SEAT
	BLIND

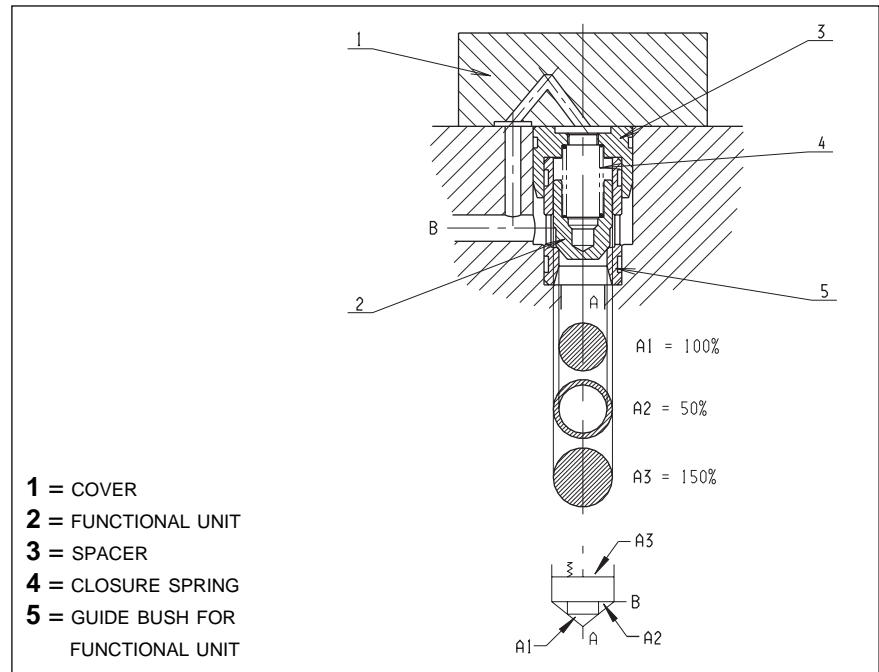

The logic unit operates as a function of the pressures acting on the relevant areas, and different opening pressures are obtained, depending on the dimensions of these areas.

A description of how to interpret the ARON cartridge opening ratios is as follows:

- there are three relevant areas A1, A2, A3;
- area A1 is taken to represent 100%, i.e. it is the reference area;
- area A2, when a 2:1 ratio is shown, is equal to 50% of area A1 and all the other ratios shown in the Table 2 can be calculated on this basis.

As consequence of these area ratios there are different opening pressures whether proceeding from A → B or from B → A.

ORDERING CODE

<b>KEL</b>	Logic element 2/2
<b>**</b>	<b>16</b> = NG16 <b>25</b> = NG25
<b>*</b>	Function: see table 1 Areas ratio: <b>U</b> = 1 : 1 <b>S</b> = 12.5 : 1 <b>B</b> = 2 : 1 (for version with drilled poppet see CF variant) <b>F</b> = 2 : 1 <b>R</b> = 2 : 1
<b>*</b>	Opening pressure (bar) (Tab.1 pressure values) (Tab.2 spring's colour and code)
<b>**</b>	Calibrated orifices: <b>00</b> = blind <b>08</b> = 0.8 mm <b>09</b> = 0.9 mm <b>10</b> = 1.0 mm <b>12</b> = 1.2 mm <b>14</b> = 1.4 mm
<b>**</b>	<b>00</b> = No variant <b>V1</b> = Viton <b>CF</b> = With drilled poppet only for KEL.**.B...
<b>2</b>	Serial No.

Tab. 1 - SYMBOL, FUNCTION, AREA RATIO AND OPENING PRESSURE

Function	Symbol	Area ratio	Code	Opening pressure (bar)	
				A→B	B→A
Directional (U) (normally used for relief valve)		<b>A1 : A3</b> 1 : 1	KEL*.U.L.00... KEL*.U.M.00... KEL*.U.H.00... KEL*.U.J.00...	<b>L</b> = 0.3 <b>M</b> = 1.6 <b>H</b> = 4 <b>J</b> = 9	
Directional (U) with orifice		<b>A1 : A3</b> 1 : 1	KEL*.U.L.**... KEL*.U.M.**... KEL*.U.H.**...	<b>L</b> = 0.3 <b>M</b> = 1.6 <b>H</b> = 4	
Directional (S)		<b>A1 : A2</b> 12.5 : 1	KEL*.S.L.00... KEL*.S.M.00... KEL*.S.H.00...	<b>L</b> = 0.3 <b>M</b> = 0.6 <b>H</b> = 1.5	<b>L</b> = 4 <b>M</b> = 8 <b>H</b> = 20
Directional (S) with orifice		<b>A1 : A2</b> 12.5 : 1	KEL*.S.L.**... KEL*.S.M.**... KEL*.S.H.**...	<b>L</b> = 0.3 <b>M</b> = 0.6 <b>H</b> = 1.5	<b>L</b> = 4 <b>M</b> = 8 <b>H</b> = 20
Directional (B) (normally used for check valve)		<b>A1 : A2</b> 2 : 1	KEL*.B.L.00... KEL*.B.M.00... KEL*.B.H.00...	<b>L</b> = 0.5 <b>M</b> = 1 <b>H</b> = 2.5	<b>L</b> = 1 <b>M</b> = 2 <b>H</b> = 5
Flow control (F)		<b>A1 : A2</b> 2 : 1	KEL*.F.L.**... KEL*.F.M.**... KEL*.F.H.**...	<b>L</b> = 0.5 <b>M</b> = 1 <b>H</b> = 2.5	<b>L</b> = 1 <b>M</b> = 2 <b>H</b> = 5
With sensitized cover (R)		<b>A1 : A2</b> 2 : 1	KEL*.R.L.00... KEL*.R.M.00... KEL*.R.H.00... KEL*.R.J.00...	A → B	
				NG16	NG25
				<b>L</b> = 0.7 <b>M</b> = 1.5 <b>H</b> = 4	<b>L</b> = 0.6 <b>M</b> = 1.5 <b>H</b> = 3.5 <b>J</b> = 9

Tab. 2 - SPRING'S COLOUR AND CODE

Spring type	U		S		B-F		R	
	NG16	NG25	NG16	NG25	NG16	NG25	NG16	NG25
Cod. L	without colour	red	without colour	red	without colour	red	without colour	red
Cod. M	green	yellow	red	green	red	green	red	green
Cod. H	blue	blue	yellow	yellow	green	yellow	green	yellow
Cod. J		without colour						blue

Tab. 3 - COVERS HYDRAULIC SYMBOLS

Type	Symbol
<b>KEC.**.RI.**.2</b> Directional with external piloting	
<b>KEC.**.CQ.**.2</b> Directional with stroke adjustment	
<b>KEC.**.RC.**.2</b> Directional with interface NG6	
<b>KEC.**.PC.**.2</b> With hydraulic outlet pilot valve	
<b>KEC.**.SH.**.2</b> With built-in-exchange valve (shuttle)	
<b>KEC.**.SP.**.2</b> With built-in-exchange valve (shuttle) and interface NG6	

COVERS FOR LOGIC ELEMENTS

COVERS ORDERING CODE

<b>KEC</b>	Covers for logic element 2/2
<b>**</b>	<b>16</b> = NG16 <b>25</b> = NG25
<b>**</b>	Type of cover (see Tab. 3) <b>RI</b> = Directional with external piloting <b>CQ</b> = Directional with stroke adjustment <b>RC</b> = Directional with interface NG6 <b>PC</b> = With hydraulic outlet pilot valve <b>SH</b> = With built-in-exchange (shuttle) <b>SP</b> = With built-in-exchange and interface NG6
<b>**</b>	<b>00</b> = No variant <b>V1</b> = Viton
<b>2</b>	Serial No.

HYDRAULIC MOUNTING SCHEMES FOR KEC COVERS AND KEL LOGIC ELEMENTS

<p><b>KEC.16/25.RI...</b> <b>COVER WITH EXTERNAL PILOTING PORT</b></p> <p>A = External piloting X allows flow in both directions A → B and B → A. B = For rapid sequence safety circuit; A → B flow is allowed; when pressure reaches X valve closes. Only for CF variant (KEL.**.B... with drilled poppet), with no pressure in X it operates as a check valve between A and B.</p>	
<p><b>KEC.16/25.CQ...</b> <b>COVER WITH STROKE LIMITATION</b></p> <p>Allows flow regulation in both directions A → B and B → A. By limiting the spool stroke the flow in both direction can be limited.</p>	
<p><b>KEC.16/25.RC...</b> <b>COVER WITH INTERFACE NG6</b></p> <p>These covers have one mounting surface preset for a solenoid pilot valve. Proper connection of Y and Z2 to the A and/or B ports will allowing piloting of the valve opening and closing functions.</p>	
<p><b>KEC.16/25.PC...</b> <b>COVER WITH HYDRAULIC RELEASE PILOT VALVE</b></p> <p>This is a cover with external piloting to be connected to B port to obtain the standard unit function. Z1 pressure piloting allows flow transfer from B → A. Normally, in order to ensure the holding condition the main port B is connected to the load; piloting in Z1 should be at least 50% of the load pressure in B.</p>	
<p><b>KEC.16/25.SH...</b> <b>COVER WITH INTEGRAL CHANGEOVER VALVE</b></p> <p>The logic element closes as function of the larger pressure in X and Z1, selected by the shuttle valve.</p>	
<p><b>KEC16/25.SP... COVER WITH INTEGRAL CHANGEOVER VALVE AND INTERFACE NG6</b></p> <p>The AP branch of the cartridge valve spring is connected with the pilot valve port. External piloting operates from Z2 → A of the pilot valve. An example is shown in the diagram of a type of connection used to keep the conical seat valve closed on both sides (interrupted flow both from A → B and from B → A).</p>	
<p><b>KRA.16/25... COVER WITH ELECTRICAL CONTROL OF THE CLOSED POSITION AND INTERFACE NG6</b></p> <p>See cartridge type KRA... next pages</p>	

5